

REVISIONS			
REV. NO.	TEM NO.	DESCRIPTION	DATE

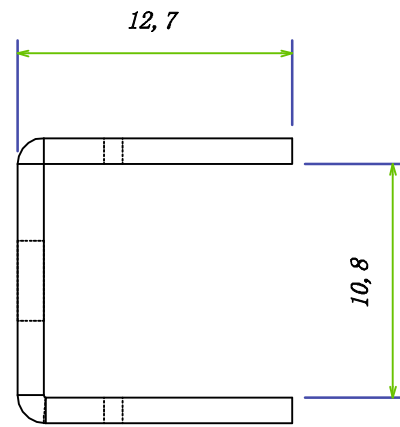
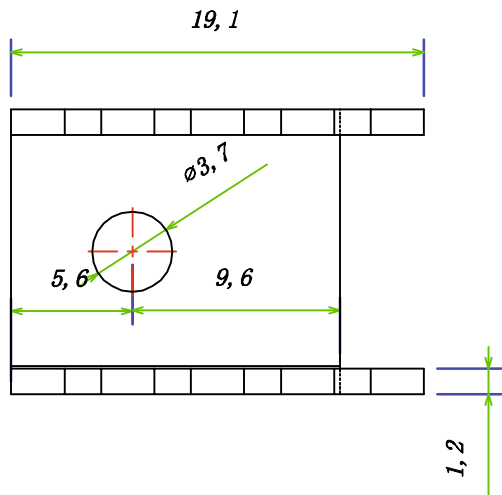
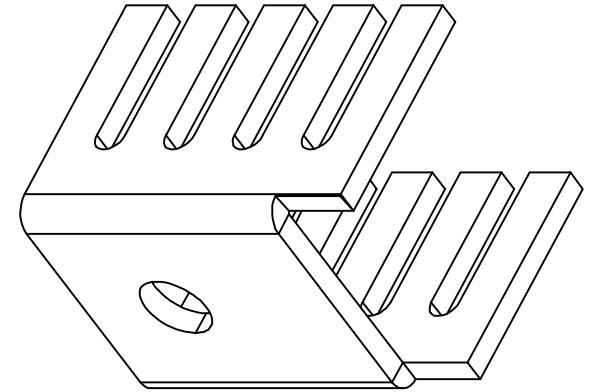
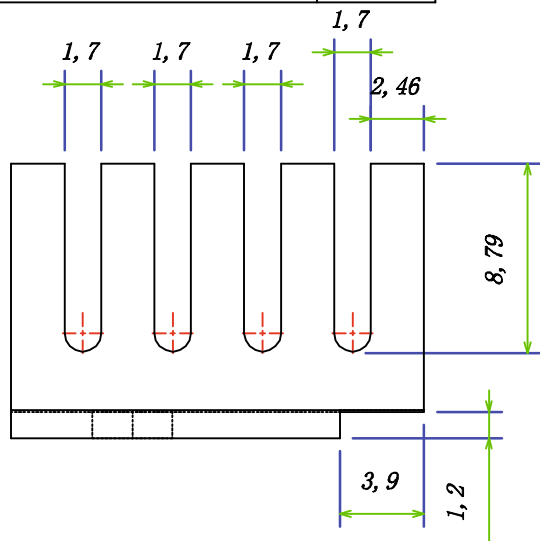

ISO 2768		PART NAME		SCALE		DO-3A			
0-6	±0.05	PART NO.		SCALE	1:1				
6-30	±0.1	MATERIAL	AL	SHEET	1 OF 1				
30-120	±0.2	DWG NAME		REV. NO.	01	DRAWN		DATE	
120-400	±0.3	UNIT	mm	THIRD ANGLE PROJECTION		CHECKED		DATE	
ANGLE	±0.5°	SHRINKAGE				APPROVED		DATE	